



**EDS**  
Energy Design Solutions

# THE NEW REVOLUTIONARY GREEN SOLUTION

for  
Solar Water Heating

*Hot water anytime anywhere*

*Liberty Box™ changes the way people have been using solar water heaters for the past 30 years!*





# What we offer you



**Liberty Box uses energy from the sun to power your existing electric water heating system**

**Liberty Box™ is the ideal heating solution for areas where traditional solar water heating will not function, or will be jeopardized by freezing temperatures.**

Simply install rooftop solar PV collectors and the in-house, reliable, small, environmentally friendly Liberty Box to start enjoying the benefits of solar radiation anywhere and dramatically lower your usage costs!

Since the heated water acts as the energy capacitor, no batteries are required. Furthermore – the Liberty Box is 100% transportable, meaning that it can move when you do!

By installing the Liberty Box in your home, everyone benefits – contractors, home owners and the environment.

With the technologically superior, green solution from EDS-USA, you will:

### Say YES to:

- Energy conservation
- Money savings
- Environment protection
- Warmer water in colder temperatures
- Wise and safe investment

### Say NO to:

- Complicated and expensive installations
- Heavy rooftop solar collectors
- Copper, soldering, leaks, pumps
- High heating and maintenance expenses
- Freezing solar elements and pipes

American made, environmentally friendly and cost-effective, the Liberty Box is the ideal technologically superior green solution to all water heating issues. Whether you want to increase the value of your home, create more energy efficient buildings or to install a more cost-effective system, EDS provides you with the tool to achieve it.



**EDS**  
Energy Design Solutions

# How it works

## The Liberty Box™

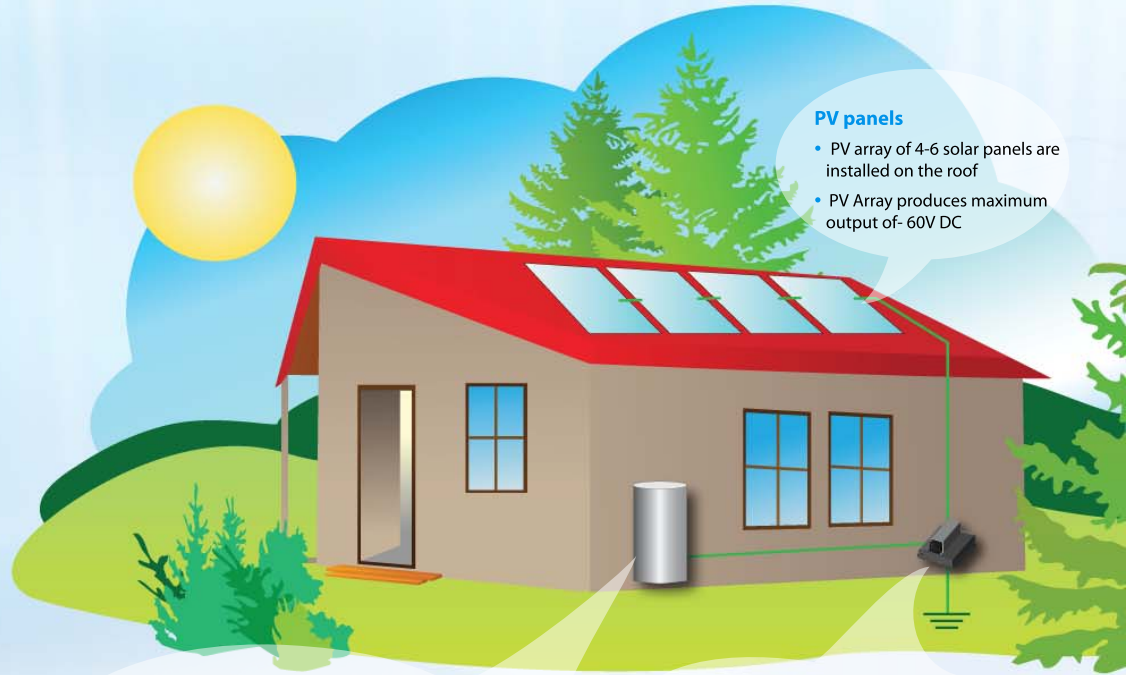
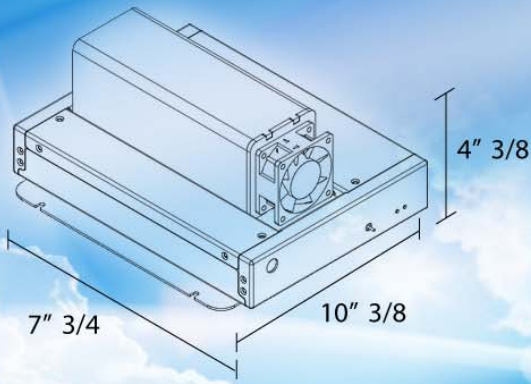

### PV panels

- PV array of 4-6 solar panels are installed on the roof
- PV Array produces maximum output of- 60V DC

### Standard water heater

- Upper heating element connected to the AC GRID
- Lower heating element connected to the liberty box
- Any existing electrical water heater, for instance 120, 80 gallon or 65 gallon models

### Liberty Box™

- Liberty Box is wall mounted near the water heater .
- Liberty Box connections:
  1. Input wires up to 30A each – connected from solar panels
  2. Output wires 15A each – connected to the water heater
  3. Ground wire - connected to Electrical Service Ground

### Installation of PV Panels by the manufacturers instructions, and:

- Disconnect the upper and lower heating elements in electric water heater
- Reconnect the upper connection to AC GRID
- Reconnect the lower connection and the thermostat to the Liberty Box
- The Liberty Box does not require additional power input
- Installation by authorized electrician only
- Typical installation should take less than half a day



Contact us now for further information on the system, installations, distributors and resellers



**USA- EDS HQ**

*EDS USA INC*  
*[Energy Design Solutions]*

*Telephone 877-340-3001*  
*info@usa-eds.com*  
*support@energy-ds.com*  
*www.energy-ds.com*



**North America**  
**Master Distributor**

*viktor@presolarnet.com*  
*info@presolarnet.com*  
*www.presolarnet.com*